

**Part Number: PT924-47160**

**Kit Contents**

Item #	Quantity Req.	Description
1	1	Rear Bumper Protector
2	1	Installation Instruction Sheet
3		

**Hardware Bag Contents**

Item #	Quantity Req.	Description
1		
2		
3		

**Additional Items Required For Installation**

Item #	Quantity Req.	Description
1		
2		
3		

**Conflicts**

Rear Bumper Applique
----------------------

**Recommended Tools**

<b>Personal &amp; Vehicle Protection</b>	<b>Notes</b>
<b>Special Tools</b>	<b>Notes</b>
Surface Thermometer	Infrared Non-contact
Heat Gun	Master Heat Gun HG-301A or equivalent
<b>Installation Tools</b>	<b>Notes</b>
Clean lint free cloths	
<b>Special Chemicals</b>	<b>Notes</b>
Cleaner	VDC Approved Cleaner (i.e. 3M Prep Solvent-70 or Isopropyl Alcohol)

**General Applicability**

All Prius models
------------------

**Recommended Sequence of Application**







Item #	Accessory
1	
2	
3	

\*Mandatory

**Vehicle Service Parts** (may be required for reassembly)

Item #	Quantity Req.	Description
1		
2		
3		

**Legend**

	<b>STOP:</b> Damage to the vehicle may occur. Do not proceed until process has been complied with.
	<b>OPERATOR SAFETY:</b> Use caution to avoid risk of injury.
	<b>CAUTION:</b> A process that must be carefully observed in order to reduce the risk of damage to the accessory/vehicle and to ensure a quality installation.
	<b>TOOLS &amp; EQUIPMENT:</b> Used in Figures calls out the specific tools and equipment recommended for this process.
	<b>REVISION MARK:</b> This mark highlights a change in installation with respect to previous issue.
	<b>SAFETY TORQUE:</b> This mark indicates that torque is related to safety.

Care must be taken when installing this accessory to ensure damage does not occur to the vehicle. The installation of this accessory should follow approved guidelines to ensure a quality installation.

These guidelines can be found in the "Accessory Installation Practices" document.

This document covers such items as:-

- Vehicle Protection (use of covers and blankets, cleaning chemicals, etc.).
- Safety (eye protection, rechecking torque procedure, etc.).
- Vehicle Disassembly/Reassembly (panel removal, part storage, etc.).
- Electrical Component Disassembly/Reassembly (battery disconnection, connector removal, etc.).

Please see your Toyota dealer for a copy of this document.

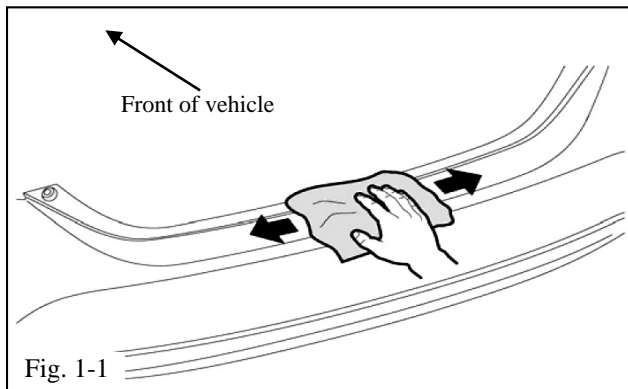

## 1. Prepare the Vehicle.

(a) Open the package and check for damage.

**!** (b) Ensure the rear bumper protector and the vehicle bumper are between 60°F (15°C) and 109°F (43°C).

(c) Open the trunk lid.

(d) Saturate a clean lint free cloth with VDC-approved cleaner (i.e. 3M™ Prep Solvent-70 or isopropyl alcohol) and clean the top surface of the rear bumper (Fig. 1-1).

(e) Wipe the cleaned bumper surface with a clean, dry, lint free cloth.

**!** **NOTE:** When using 3M™ Prep Solvent-70, follow the manufacturer directions. Do not allow the cleaner to air dry on the part.

**!** **NOTE:** Once cleaned, do not contaminate this surface by touching it with bare skin.

## 2. Install the Rear Bumper Protector.

(a) Carefully hold the rear bumper protector by its edges and pull all of the plastic liner tabs at the ends of the tapes to expose approximately 1½" (40mm) of tape (Fig. 2-1).

**!** **NOTE:** Once the liner is removed from the rear bumper protector, the surface of the tape must not be touched.

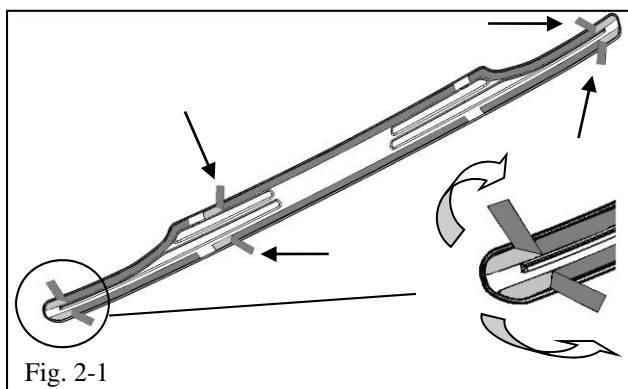

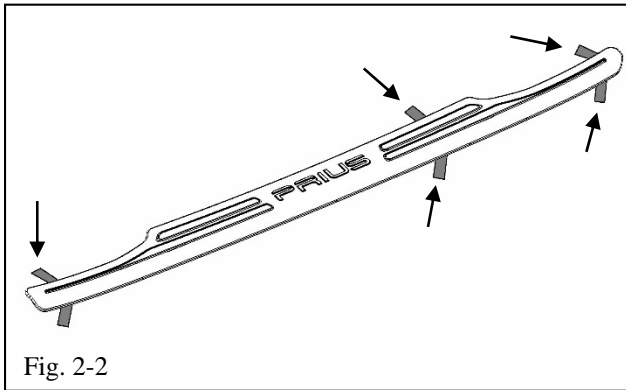

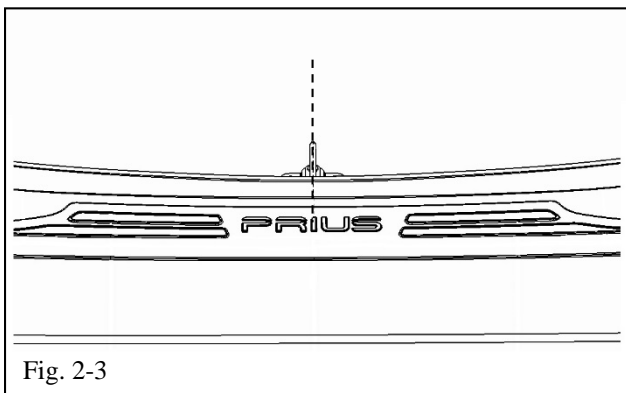

- (b) Ensure all of the tabs are folded so they can be accessed from the top once the protector is placed on the rear bumper (Fig. 2-2).

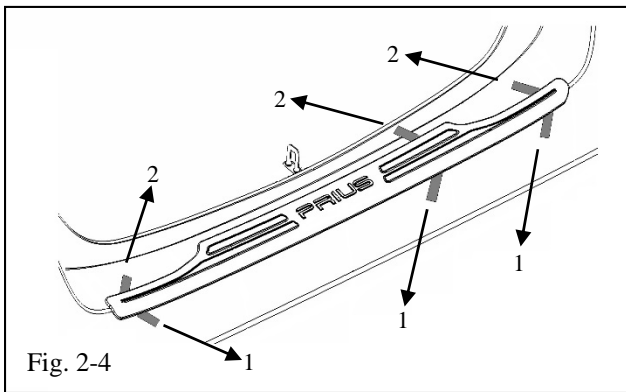

- (c) Align the 'I' in the PRIUS logo with the lift gate striker (Fig. 2-3).
- (d) While keeping the rear bumper protector aligned, lower the right hand corner until it contacts the bumper and starts to stick. Use a rolling motion and press the rest of the protector from right to left. **Do not** allow both ends of the protector to stick to the bumper before the center touches.



- (e) Once the exposed tape has been secured, pull out and discard the liners in the order shown to allow full tape contact with the rear bumper (Fig. 2-4).

 (f) Press down firmly around the entire perimeter of the protector to ensure full adhesion of the tape to the rear bumper.

- (g) Close the trunk lid.

**TOYOTA PRIUS 2016 - REAR BUMPER PROTECTOR**  
Checklist - these points **MUST** be checked to ensure a quality installation.

<u>Check:</u>	<u>Look For:</u>
<p><u>Accessory Function Checks</u></p> <p><input type="checkbox"/> Visual alignment</p> <p><input type="checkbox"/> Proper tape adhesion</p>	<p>The bumper protector should be visually centered left to right, centered to the strike latch</p> <p>The front edge of the bumper protector should appear visually parallel to the vehicle bumper</p> <p>The protector lip should align with the contour of the bumper surface</p> <p>A gap of approximately 1mm (0.04”) is designed to exist under the edges of the protector and the bumper</p> <p>No gap is allowed between the tape and the bumper</p>
<p><u>Vehicle Function Checks</u></p> <p><input type="checkbox"/> Confirm trunk lid closes properly</p> <p><input type="checkbox"/></p> <p><input type="checkbox"/></p>	<p>The protector must not hinder the closure of the trunk lid</p>
<p><u>Vehicle Appearance Check</u></p> <p><input type="checkbox"/> After accessory installation and removal of protective cover(s), perform a visual inspection.</p>	<p>Ensure no damage (including scuffs and scratches) was caused during the installation process. (For PPO installations, refer to TMS Accessory Quality Shipping Standard.)</p>